



Properties of the Entomoparasitic Nematodes (*Heterorhabditis bacteriophora*) Liquid Culture using a Helicoidal Ribbon Agitator as Rheometric System

Diola-Marina Núñez-Ramírez¹, Luis Medina-Torres^{2*}, Fausto Calderas³ and Guadalupe Sanchez-Olivares⁴

¹Durango Institute of Technology, Department of Chemical and Biochemical Engineering, Felipe Pescador # 1803 Ote. CP 34080, Durango, Durango, Mexico

²Department of Chemical Engineering, Joint E, National Autonomous University of Mexico (UNAM), Mexico, DF 04510, Mexico

³Institute of Materials Research, National Autonomous University of Mexico (UNAM), Mexico, DF 04510, Mexico

⁴CIATEC, A.C. Omega 201, Fracc. Industrial Delta, CP 37545, León, Gto., México

Abstract

The rheological parameters: flow behaviour index n , flow consistency index K and effective viscosity η_e were estimated for the entomoparasitic nematodes *Heterorhabditis bacteriophora* liquid broth at different culture maturation times. The nematode or nematodes were cultivated during 20 days in a bioreactor, and the growth media inside the bioreactor was enriched with protein and fat sources. Rheological parameters for the heterogeneous suspension were estimated with mixer principles employing a helical ribbon agitator fixed to a rheometer. As the culture matured, n decreased from 0.8 to 0.2 (-) and K increased up to 1200 mPa·s n ; η_e showed a non-Newtonian ($n < 1$) behaviour, η_e reached peak values of 0.32 Pa·s for a rotational speed of 0.5 revolutions per second (rps) and 0.048 Pa·s for 2.5 rps. Rheological properties reported here could be more reliable as compared to those reported for non-homogeneous liquid fermentations where estimations were performed with conventional geometries (i.e. concentric cylinders) which are appropriate for homogeneous systems but not for non-homogeneous ones.

Keywords: Entomoparasitic nematodes (EPNs) growth; Fermentation broth rheology; Helical ribbon agitator; Rheometric

Introduction

Heterorhabditis bacteriophora are microscopic entomoparasitic nematodes (EPNs) that are attractive as organic alternatives for controlling a wide range of crop insect pests. EPNs evolved with parasitic adaptations that enable them to “feast” upon insect hosts. The infective juvenile, a non-feeding, developmentally arrested nematode stage, is destined to seek out insect hosts and initiate parasitism. After an insect host is located, EPNs enter the insect body through natural openings or by cuticle penetration. Upon access to the insect hemolymph, bacterial symbionts (*Photorhabdus luminescens* for *H. bacteriophora*) are regurgitated from the nematode intestines and rapidly proliferate. During population growth, bacterial symbionts secrete numerous toxins and degradative enzymes that exterminate and biotransform the host insect. During development and reproduction, EPNs obtain their nutrition by feeding upon both the bioconverted host and proliferated symbionts. In general, EPNs are analogous to each other by the fact that their life cycle consists of five stages of development. Furthermore, reproduction is much more complex and varies between genera and species [1]. This study attempts to rheological behaviour of EPNs in liquid media. Entomoparasitic nematodes (EPNs) *Heterorhabditis bacteriophora* are utilized as bio control agents against various insect pests of agricultural significance. EPN is an attractive organic alternative to chemical insecticides as they do not pose a threat to the environment. Additionally, EPNs are particularly safe for use around humans, livestock, and plants [2]. The close symbiotic relationship between EPNs and their bacterial counterparts contributes to the safety and efficacy of their use as biological control agents. Liquid fermentations are becoming an industrial common way to produce several benefactors in this century [3]. However, yield in these processes is limited to the efficiency reached in the mass transfer during operation. Mass transfer is strongly dependent on the flow regime conditions promoted by several factors such as media composition, culture properties including density and rheological behaviour [4,5], operation of the system and also vessel design and geometry [6,7]. Fermentation broth cultures are frequently prepared in aqueous medium and contain at least one protein source, lipids and carbohydrates. Processes are carried out mainly in mechanically agitated tanks using impellers and in fewer cases in gas

agitated vessels airlift bioreactors. Most of microorganisms inoculated in cultures are unicellular, capable of metabolizing active nutrients and reproducing by cell division at very changeable rates depending on the stage of culture; at the end of process, culture media gets over populated. As the process advances, the death of some individuals occurs, this fact can be attributed to natural reasons, or in other cases death is induced by stress originated by mechanical agitation, overpopulation or nutrients ending. Death bodies remain in the culture until the process end and affect its physical properties. Mature and over populated culture medium may also contain rests of nutrients not consumed [8]. As culture evolves, changes in the flow properties of the media are easily observed e.g. broth flows too slow possibly indicating that the mass transfer process in the liquid is affected; however, not many studies have been made to seek for alternatives to overcome this phenomenon. Additionally, problems arising during nematode mass production are due to many different factors. Some of these factors include phase shifting of the bacterial symbiont, low percentages of nematode copulation, inoculum (bacterial/nematode) concentrations and fermentation parameters: oxygen concentration, pH, temperature, agitation, rheological behaviour [4,5,9]. There are different reports where rheological properties of broth were estimated for some fermentation experiment at the end of the process [8,10]; however, viscosity data are not very useful to control the process or to improve yield. Moreover, estimations of the rheology properties for a few fermentation broths have been developed using conventional geometries commonly used

***Corresponding author:** Luis Medina-Torres, Department of Chemical Engineering, Joint E, National Autonomous University of Mexico (UNAM), DF 04510, Mexico, Tel: 52-555-622-5360; Fax: 52-555-622-5329; E-mail: luismt@unam.mx

Received November 20, 2014; **Accepted** January 29, 2015; **Published** February 02, 2015

Citation: Núñez-Ramírez DM, Medina-Torres L, Calderas F, Sanchez-Olivares G (2015) Properties of the Entomoparasitic Nematodes (*Heterorhabditis bacteriophora*) Liquid Culture using a Helicoidal Ribbon Agitator as Rheometric System. J Bioprocess Biotech 5: 207 doi:[10.4172/2155-9821.1000207](http://dx.doi.org/10.4172/2155-9821.1000207)

Copyright: © 2015 Núñez-Ramírez DM, et al. This is an open-access article distributed under the terms of the Creative Commons Attribution License, which permits unrestricted use, distribution, and reproduction in any medium, provided the original author and source are credited.

for homogeneous material: concentric cylinders [11,12], a viscometer with double gap [13], or even the Brookfield-type rotational viscometer [14]. Nevertheless, results obtained with these geometries could not be representative because of the *heterogeneity* of the culture broths, which include large particles that could settle down easily and sometimes the particle size is of the same size as the annulus in the concentric cylinders [10]. Alternative geometries to estimate the rheological properties of non-homogenous systems that could monitor the Newtonian or non-Newtonian behaviour of culture broths have been proposed: helical ribbon impeller, which act as mixers do but fixed to and controlled by a rheometer [15-18]. Principles for *mixer viscometry* studies are based in the work of Metzner and Otto [19] and take into account two assumptions: laminar flow and power law behaviour.

The vane geometry has been proposed for the characterization of Newtonian behaviour suspensions with diverse nature such as paraffin oil, glycerol, silicon oil and sucrose solutions [18]. The authors also mentioned more applications for the vane, i.e. red mud suspensions, automotive greases, bentonite clay suspensions, filamentous broths, TiO₂ pigment suspensions, shaving foams, etc., but these systems present problems in the sedimentation as the particle size increases (> 10 µm).

On the other hand, the helical ribbon was reported to estimate more accurately the rheological properties of the non-Newtonian *Aspergillus awamori* fermentation broth [17] or kaolin suspensions at different concentrations (<65%, w/v) [16]. The rheological characterization for the coarse suspensions presented so far may be wide, but the culture broth characterization of more complex microorganisms as nematodes (EPNs) requires an accurate study; moreover, nematodes are multicellular organisms and coexist with a symbiotic bacterium which could influence in the complexity of their rheological response.

The culture of certain nematodes is of great interest because they are pathogen to certain insect pests in crops and can serve as biological agents as an alternative to biochemical insecticides. The two usually used with this purpose are the *Heterorhabditis* and *Steinernema* [9,20]. Nematode production (EPNs) by liquid fermentation could last more than two weeks, and although nematodes are being sold recently in the international market [21], their *in-vitro* liquid process is not well controlled. This is evidenced when results found in literature are compared and high variability is found [20], no matter the conditions that authors choose to produce them. The nematodes liquid culture rheometry has been studied previously by Young et al., [8]. The rheological properties were estimated using cone-plate or concentric cylinders geometries, broth behaviour was reported as non-Newtonian fluid and the authors assumed that rheological properties could have strong effects during operation or in the downstream process. In both studies, the non-Newtonian viscosity for the nematodes (EPNs) was presented as a function of the applied shear rate $\dot{\gamma}$ and was described satisfactorily by two parameter power law model (Equation 1):

$$\eta = K \cdot (\dot{\gamma})^{n-1} \quad (1)$$

where, K is the consistency index (Pa·sⁿ) and $n(-)$ is the fluid behaviour index (dimensionless).

Young et al. [8] reported a range of values for K between 29 and 117 mPa·sⁿ, values for n were between 0.64 and 0.84 (-) for mature culture broths for the three species *Steinernemafeltiae*, *Heterorhabditismegidis* and *Phasmarhabditis hermaphrodita*; which represents one of the first attempts to study the rheological properties for the EPNs culture broth. However, values reported were obtained using geometry of concentric

cylinders. As described before, when multiphase systems are sheared in concentric cylinders, “*slip*” may occur [22], to correct this error, mixer viscometry could work. The importance of this work was to apply the helical ribbon agitator to estimate the rheological properties n , K and η_e of the liquid broth of *Heterorhabditis bacteriophora* nematodes (EPNs) as the culture evolves, a comparison of viscosity is also presented for media with several nematode concentrations.

Materials and Methods

Biological culture features and rheological properties determinations

Mass production in liquid media, regardless of the culturing vessel, requires the nematode culturing media to be conditioned [23]. Conditioning of the liquid medium refers to the inoculation of the appropriate bacterial symbiont. This step is crucial as the bacterial symbionts:

- 1) Convert the complex medium into easily accessible components for both self and partner nematodes;
- 2) Secrete necessary metabolites, (food signals, antibiotics, pigments, etc.); and
- 3) Serves as the main food source for the developing nematodes.

The nutritional relationship is highly specific for *Heterorhabditis*, because these nematodes cannot be cultured under axenic conditions or on other bacteria. The liquid media tested are presented in Table 1. Broth aspect for samples extracted at different times is showed in Figure 1. Figure 1a correspond to a light microphotograph showing the aspect of a fresh culture at day 2 seen with 1000X magnification where high population of the symbiotic bacterium (length ≈ 3.5 µm) is appreciated, also the abundant oil content at this time is notorious (at least 1.25%, v/v depending on the experiment). Figure 1b presents some physiological stages of culture at day 8, differences can be observed in the characteristics for young and old individuals, rests of the remaining solids from the initial nutrients can be observed his stages are featured and differentiated by their shape, size, density, weight and metabolism activity [9,24]. Individuals showed in Figure 1c are notably different, they have more uniform features, this nematode stage is the desirable and is known as “infective juvenile”, this image corresponds to a mature culture (day 20). A pair of 25 mL samples was extracted from the culture broth periodically from cultures developed in the bioreactor or shake bottle (Table 1) in order to estimate their rheological properties. All samples were sheared at 25°C in a 25 mL Vessel-Helical ribbon agitator system (Figure 2) coupled to the TA model AR-G2 rheometer with temperature control and with a maximum torque (T) of 1.022×10^{-3} Nm and a maximum rotational speed (N) of 100 rpm. Data obtained for T and N were treated as follows to obtain n , K and η_e according to the method proposed by Brito-de la Fuente et al. [16].

Estimation of rheological properties n , K and η_e

The viscometric flow condition during helical ribbon agitation was maintained during all tests. A sample of 25 mL of the growth media was taken to measure the rheological properties in all experiments. High precision measurements of torque and impeller rotational speed for the given impeller geometry were converted into what is termed as a “*process viscosity*”. From the applied rotational speed (N) and the torque measurement (T), a classical flow curve was obtained to apply the mixer principles [19]:

Firstly, a power constant (K_p) for Newtonian mixtures into

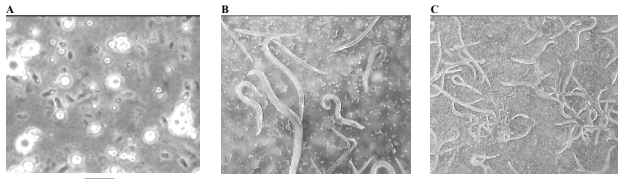

Figure 1: Light microphotographs of samples before shearing belonging to *Heterorhabditis bacteriophora* culture broth produced in shake bottle or in a bioreactor, using whey or aguamiel in media formulation: (a) at day 2, bar length = 10 μm , magnification 1000X, (b) at day 8, bar length = 500 μm , magnification 40X. (c) Mature culture at day 20 bar length = 500 μm , magnification 40X.

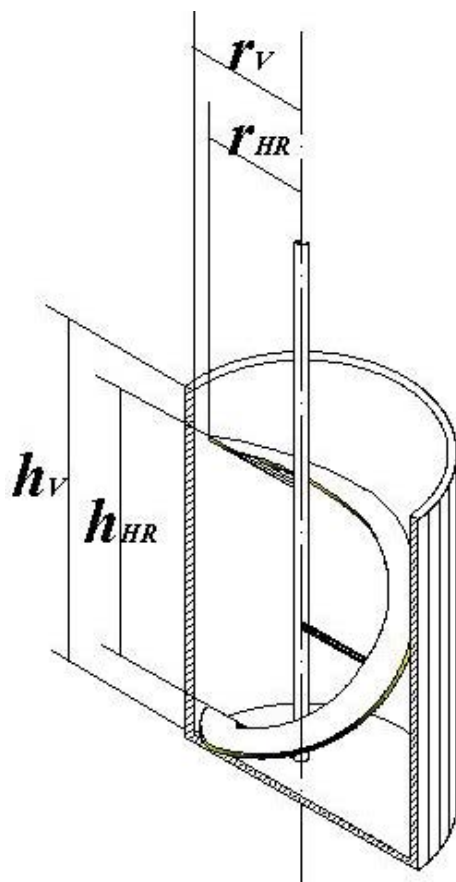

Figure 2: Vessel-Helical ribbon agitator system used to estimate the rheological properties of the *nematode* culture broth. Main dimensions expressed in mm: $r_V = 14.5$, $r_{HR} = 12.4$, $h_V = 40.0$, $h_{HR} = 31.5$.

laminar region is represented by Equation 2:

$$K_p = \frac{2 \cdot \pi \cdot T}{N \cdot d^3 \cdot \mu} \quad (2)$$

Where, K_p is a function of the geometry for Newtonian fluid behaviour, d is the impeller diameter, N rotational speed, T torque and μ is the Newtonian viscosity.

Secondly, it was considered that non-Newtonian fluid follows the power law behaviour ($\tau = \mu(\dot{\gamma})$), Equation 1) where τ is the shear stress, $\dot{\gamma}$ is the shear rate and assuming a characteristic function N :

$$K_p(n) = \frac{2 \cdot \pi \cdot T}{K \cdot d^3 \cdot N^n} \quad (3)$$

Where, K represents the consistency index. Expressing Equation 3 in explicit for T gives:

$$T = \frac{K_p(n) \cdot K \cdot d^3 \cdot N^n}{2 \cdot \pi} = A(n) \cdot N^n \quad (4)$$

In the Equation 4 the last term is simplified, where $A(n)$ is a function of shear stress and represents:

$$A(n) = \frac{K_p(n) \cdot K \cdot d^3}{2 \cdot \pi} \quad (5)$$

For a mixed system, A depends on the behaviour index of the fluid n . The factors n and K required in Equation 3 can be determined if $K_p(n)$ is known. Brito-de la Fuente et al. [16] developed a function of $K_p(n)$ on K_p for the helicoidally impeller used. Considering only Newtonian behaviour, Brito-de la Fuente proposed the value:

$$K_p = 162.55 \pm 1.04.$$

while, for non-Newtonian behaviour, the following equation was proposed:

$$K_p(n) = K_p \cdot b^{n-1} \cdot c^{\left[\frac{n-1}{n}\right]} \quad (6)$$

Equation 6 uses pre-determined values for a and b :

$$b = 24.64 \pm 2.76 \text{ (dimensionless)}$$

$$c = 0.91 \pm 0.02 \text{ (dimensionless)}$$

Finally, process viscosity can be calculated from Equation 7:

$$\eta_e = \frac{K \cdot K_p(n) \cdot N^{n-1}}{K_p} \quad (7)$$

In Equation 7, the relationship $[K_p(n)/K_p]$ represents a proportionality constant (K_s) that correlates the shear rate as a function of the rotational speed (Equation 8):

$$\dot{\gamma} = K_s \cdot N \left[\frac{K_p(n)}{K_p} \right]^{\frac{1}{n-1}} \cdot N \quad (8)$$

It must be noted that shift factor $(1/n-1)$ is used to correlate the non-Newtonian power consumption $K_p(n)$ with the corresponding

Experiment	Media and production system*	Nematode concentration (C_n) $\times 10^3$ [nematodes/mL] at day 20
E1	50% whey, B	222
E2	8.2% AM, B	192
E3	27.6% AM, B	160
E4	8.2% AM, Sb ¹	57
E5	8.2% AM, Sb ²	166
E6	8.2% AM, Sb ³	124
E7	27.6% AM, Sb ⁴	200

*All media was produced at 25°C during 20 days and enriched with yeast extract, corn oil (co) and egg yolk (ey) at several proportions in order to promote the nematode growth. All concentrations are expressed in percentage v/v or w/w depending if ingredient is liquid or solid

Main differences in the media tested are mentioned:

¹excess: 5.3%, ²enrichment: 1.2%, ³2.5% co and 1.2% ey, ⁴2.5% co and 1.2% ey

Table 1: Main features of the seven culture broths used for the rheological tests. Abbreviations are as follows: B- Bioreactor ($V_T = 4.5$ L), Sb-Shake bottle ($V_L = 50$ mL), AM-aguamiel

Newtonian one K_p . The K_p value was previously experimentally determined for the geometry used and takes the value 162.5454 (dimensionless) [16].

Results and Discussion

Flow behaviour index, (n)

In Figure 3a, the most representative values that were estimated for the flow behaviour index [n , (-)] are plotted for experiments E1, E2 and E3, each circle filling type in Figures 3a and 3b is referred to particular experiment conditions. The earliest data presented is for samples extracted from culture at day 2 and the oldest data correspond to samples at day 20. With time, cultures liquid got overpopulated due to nematodes reproduction and it is assumed that cultures also were saturated of diverse metabolites -not studied here, neither quantified. However, the presence of these elements could be the reason for the values of n to decrease from 0.87 to 0.24(-) for the shear thinning region ($n < 1$).

In Figures 3a and 3b, the size of each circle is related to the concentration of live nematodes (C_n), counted in the sample before being sheared. At the beginning there were less than one thousands nematodes (plot for day 2, smallest circles, E1), while from day 8, there was over 70,000 nematodes (plot for E2, day 8 has medium size), in the best case the maximum C_n registered was over 170,000 nematodes (plots for E1 at days 18 and 20 are the biggest circles). It is remarkable that differences in concentrations did not present greater effects in the flow behaviour index but the consistency index did increase. Consistency index shows a linear tendency to increase with age of broth with some experimental scatter data, this result is expected since a higher nematode content occurs as time progresses and thus the zero shear rate viscosity (directly related to the K factor) of the broth also increases. However, the direct relation of the consistency index with nematode content showed to be far from linear since the interaction between nematode particles in the broth is not a simple one. As shown in Figure 3a, data in this range correspond to several concentrations of nematodes in the cultures tested, no matter if media had been formulated with aguamiel and no effect was observed with other nutrients used. As the process evolves, n values confirm the non-Newtonian culture broth behavior ($n \neq 1$, Equation 1) as reported by Young et al. [8] for the nematodes liquid culture. The authors suggested that viscosity is dependent on the shear rate; this fact should be present when designing and operating a system of this nature in order to promote and enhance mass transfer.

The minimum n values presented in this work [$n = 0.24$ and $n \approx 0.4$ (-)], estimated with mixer principles, are a little bit smaller than those estimated with coaxial cylinders: $n = 0.77$ for the case of Young et al. [8] and similar $n \approx 0.56$ for the case of Chavarría-Hernández et al. [12]. However, the minimum values reported here, were reached at several ages of the process -i.e. days 4, 10, 12, 18 and 20- for the distinct media tested. While minimum values reported elsewhere are valid only for the mature broth, i.e. day 25 [12,24]; however, the method used for the estimation of n values has to be taken into account. An assumption, for the repeated low n values reported here is that they could have been induced by several facts occurred with maturation of broth such as: growth of the bacterium, presence of the nematode released by the starter nematodes, disintegrating nematode debris, occurrence of *Endotokia matricide*. Details about these phenomena were reported for the *Heterorhabditis* nematode by Johnick and Ehlers [25]. Differences in the physiological activity, due to specialization of each stage during the nematode growth, each one has a length, diameter, mass, weight and metabolism completely different [24]. Another cause is the saturation

in media of fermentation gases and the unknown metabolites produced by the complex nematodes; some of these facts has been suggested also by Chavarría-Hernández et al. [12].

Flow consistency index, (K)

In Figure 3b, the values estimated for the Flow consistency index [K , (Pa·s ^{n})] are plotted for experiments E1, E2 and E3 with the same interpretation for symbols described for Figure 3a. The values of K shows a tendency to increase gradually as culture broths mature, but most values presented for K are placed in the range $55.93 < K < 341$ mPa·s ^{n} . Out of this range, a minimum K value is found (19.22 mPa·s ^{n}) corresponding to the E1 experiment at the earliest time (day 2). A maximum estimated value (1.25 mPa·s ^{n}) belongs to two different samples taken from cultures at different ages, the first one is for E2 at day 12 and the second one is for a mature culture (E3, day 20). They were formulated with aguamiel and contained different *Heterorhabditis bacteriophora* nematodes (EPNs) concentrations (for E2 $C_n \approx 83$ and for E3 $C_n \approx 160$, thousands of nematodes per millilitre respectively, these differences are represented in the size of circles in Figure 3b). As mentioned before, for the case of n , the K behaviour could be strongly affected by the transformations occurred inside of cultures. The maximum K values reported elsewhere are: 0.031 Pa·s ^{n} [8] and 0.27 Pa·s ^{n} [12], in both cases, these data were estimated using concentric cylinders and different formulations in the culture media were used. The maximum values estimated in this work for K are notably higher; in this sense, differences could be originated from the geometry used to shear samples. Results presented here were obtained using the helical ribbon, this geometry shears and keeps homogeneity simultaneously, due to a rotational and laminar regime in the condition of the agitation [16]; it is thought that values obtained by this method are more reliable specially for the heterogeneous systems which tend to sediment in other types of conventional geometry (Figure 3).

For the rheological estimations listed for cultures presented in Table 2, a non-Newtonian behaviour is observed. In all cases, rheological determinations were made using a viscometer or a rheometer with very different geometries, so results are difficult to compare; moreover, cultures nature is completely different. However, despite these differences, n values are kept always in the shear thinning region for mature broths, the most extreme case is when n reaches 0.1 (-) at day

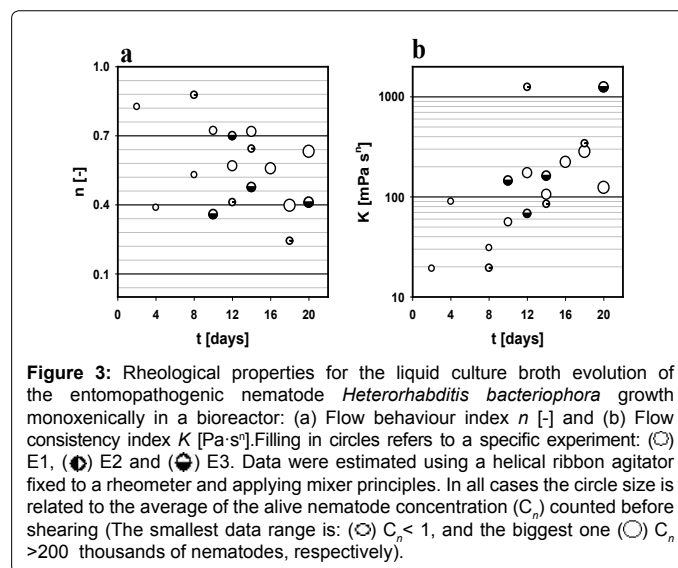

Figure 3: Rheological properties for the liquid culture broth evolution of the entomopathogenic nematode *Heterorhabditis bacteriophora* growth monoxenically in a bioreactor: (a) Flow behaviour index n [-] and (b) Flow consistency index K [Pa·s ^{n}]. Filling in circles refers to a specific experiment: (○) E1, (●) E2 and (⊙) E3. Data were estimated using a helical ribbon agitator fixed to a rheometer and applying mixer principles. In all cases the circle size is related to the average of the alive nematode concentration (C_n) counted before shearing (The smallest data range is: (⊙) $C_n < 1$, and the biggest one (○) $C_n > 200$ thousands of nematodes, respectively).

Reference	Geometry and equipment used for rheological determinations	Microbiological system studied and growth conditions	Main results	
Badino Jr <i>et al.</i> [17]	Continuous on line measurements using a helical ribbon connected to Brookfield rheometers model LV-DVIII and RV-DVIII (Brookfield Eng. Lab. Inc.)	Mycelial growth of <i>Aspergillus awamori</i> in a 10 L fermentor agitated with impellers (300 < N < 700 rpm, 35 °C) Culture t _{max} = 30 h	1 > n > 0.3 (-)	K < 2 Pa·s ⁿ
Juárez-Sánchez <i>et al.</i> [13]	Haake viscometer equipped with a double gap system (Rotovisco RV20)	Plant cell culture of <i>Beta vulgaris</i> V _L = 6 L growth in airlift biorreactor (V _T = 10 L, 26°C) Culture t _{max} = 21 d	0.7 > n > 0.5 (-)	K < 300 mPa·s ⁿ
Müller <i>et al.</i> [11]	C25 Concentric cylinders connected to a rheometer (Bohlin Rheologi, AB)	Batch cultivation of <i>Aspergillus oryzae</i> , V _L = 4.5L (N < 900 rpm, 30°C) Culture t _{max} = 60 h	0.4 > n reported for culture times of 27 < t < 40 h (biomass < 23 g/Kg)	K < 55 Pa·s ⁿ reported for culture times of 27 < t < 40 h (biomass < 23 g/Kg)
Chavarría-Hernández <i>et al.</i> [12]	Concentric cylinders coupled to Haake-5M viscometer (PV20 rotovisco)	<i>S. carpocapsae</i> growth with the symbiotic bacterium <i>X. nematophila</i> in agitated bottles (22°C) Culture t _{max} = 25 d	n > 0.6	K < 0.27 Pa·s ⁿ
Raposo and Lima-Costa [14]	Rotational viscometer (Brookfield type)	Plant cell suspension cultures of <i>Centaurea calcitrapa</i> Shake flasks V _L = 0.5 L (115 rpm 22°C) Culture t _{max} = 10 d	0.4 > n > 0.18	K < 0.6 Pa·s ⁿ
		Plant cell suspension cultures of <i>Centaurea calcitrapa</i> in biorreactor (V _L = 1.5 L, agitated with double pitched-blade turbine N < 250 rpm, 24°C) Culture t _{max} = 14 d	0.6 > n > 0.1	K < 1.8 Pa·s ⁿ
Gögüs <i>et al.</i> [10]	Rotational viscometer (Brookfield DV II+)	Liquid fermentation of <i>Aspergillus sojae</i> ATCC 20235 in agitated flasks V _L = 50 mL (250 rpm, 30°C) Culture t _{max} = 96 h	η (γ̇ < 250 1/s) < 0.006 Pa·s growth in a complex media ACDSB	
E1, E2 and E3 of this work	Helical ribbon coupled to a rheometer (TA G2)	<i>nematode</i> growth with the symbiotic bacterium <i>X. nematophila</i> in bioreactor (25°C) Culture t _{max} = 20 d	0.4 < n < 0.7 from day 8 to 20	K < 1.25 Pa·s ⁿ
E4 to E7 of this work	Helical ribbon coupled to a rotational rheometer (TA G2)	<i>Heterorhabditis bacteriophora</i> <i>nematode</i> growth with the symbiotic bacterium in shake bottles (150 rpm, 25°C) Culture t _{max} = 20 d	0.24 < n < 0.87 at day 20	K < 1.25 Pa·s ⁿ

Table 2: Rheological properties estimated for the culture broth of some microorganisms produced in submerged cultures employing several kinds of geometries

14 in the production of plant cells of *Centaurea calcitrapa* carried out in a bioreactor agitated with a double pitched-blade turbine [14]. For the case of K values, they present a tendency to increase and the highest value was reached also for the culture of plant cells *Beta vulgaris* (300 mPa·sⁿ), growth in bioreactor during 21 days.

Representative samples for the rheological measures were taken according to the evolution of the total live nematode content, which represent the maximum content after an exponential growth (day 20). This result was considered the basis to estimate the maximum total growth for experiments E1-E7. Whereas for minimum nematode contents, experiments E1 and E2 were taken as a reference (day 2).

From procedures and data reported in Table 2, it can be inferred the necessity to design a standard system to formally study the rheological evolution of liquid fermentations taking into account the complexity and heterogeneity that these systems show. The most representative rheological data for all experiments of this work (E1 to E7) estimated when cultures had become mature (day 20) are compared as a function of the nematode concentration reached at the end of the liquid culture (Figure 4). Figure 4 suggest certain dependency of n and K on C_n. The polynomial model of 4 parameters expressed by Equation 9 was used to fit data presented in Figure 4a and 4b:

$$f(n, k) = y_0 + a \cdot C_n + b \cdot C_n^2 + c \cdot C_n^3 \quad (9)$$

where the dependent variable y is referred to any of the two flow indexes n or K, C_n is the “non-dependent” variable and y₀, a, b and c are polynomial icular shear rate conditions of the plant cell culture *Centaurea calcitrapa*. For the case of nematodes growth, it was not found a function of rheology broth properties with concentration.

Effective viscosity, (η_e)

Process viscosity (η_e) estimated accordingly to Equation 10:

$$\left[\eta_e = \frac{K \cdot K_p(n) \cdot N^{n-1}}{K_p} \right] \quad (10)$$

Results for the experiments E1 to E3, at several stages of cultures, were plotted as function of the rotational speed, N (Figures 5 and 6). Sizes of symbols in Figure 5 have the same interpretation used in Figure 6. For the three experiments compared, the non-Newtonian viscosity reaches a higher range of values accordingly to the nematodes content (size of symbols) and changes with the rotational speed (N). The highest range for process viscosity were presented in samples of E2 and E3 experiments (Figure 5b and 5c): 0.32 > η_e(N) > 0.13 Pa·s in the range 0.5 < N < 2.5 rps (C_n = 92 for E2 and C_n = 160 for E3, thousands of nematodes/mL from 2, 8, 18 to 20 day, respectively). E1 experiment (Figure 5a), containing more than 170 thousands of nematodes/mL reported a lower range values for process viscosity: 0.24 > η_e(N) > 0.029

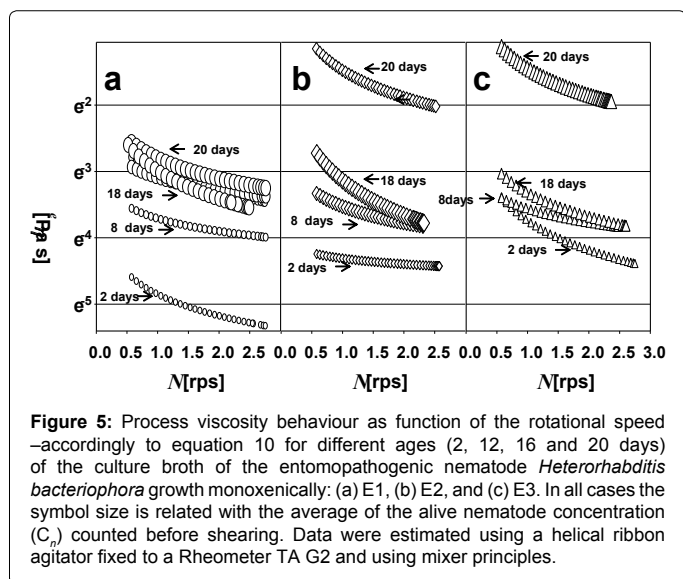
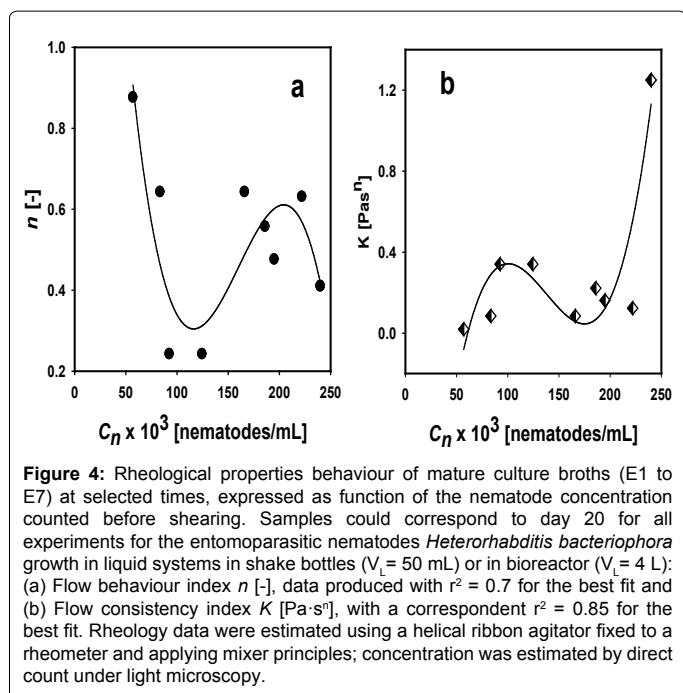

(Pa·s). Again, non-linearity behavior of process viscosity is observed for all cases, no matter which medium was used, but there is a tendency to increase viscosity of the broth as time progress. That is to say, the viscosity of the 20 day broth is the maximum viscosity in all cases (as nematode content, Table 1) and the viscosity of the 2 day broth is the minimum of all samples.

These results suggest certain influence due to the physiological activity of the symbiotic bacterium; this interpretation cannot be supported, because the bacterial production has not been followed. However, it can be mentioned that bacterium grows faster than nematode and common nematode production procedures are based in the massive colonization of bacteria before inoculate nematodes.

A comparison of the process viscosity obtained for experiments E4 to E7 (shake bottle) at the end of process (day 20) are showed in Figure

6. The behaviour shown for η_e in Figure 6 suggest a tendency for the process viscosity to increase due to the abundance of nematodes, this fact should be taken into account in the design, operation and scaling up of nematode production systems. As it was presented in Table 1, each experiment had been induced to produce different quantities of nematodes, with the lowest C_n corresponding to E4 and the highest to E7 (57 and 200×10^3 nematodes/mL respectively). This production is associated to the process viscosity because it lies in the range value for E4 experiment $0.014 > \eta_e(N) > 0.012$ Pa·s, while for E7: $0.32 > \eta_e(N) > 0.14$ Pa·s. A comparison can be made regarding the production method (shake bottle or bioreactor). For the case of the bioreactor, high maximum (day 20, Table 1) nematode contents and process viscosities (Figure 5) are achieved. Whereas for the case of the shake bottle, only one of the different broths studied (E7) achieved a high nematode content (Table 1) and high process viscosity (Figure 6) which establishes the optimum conditions for this method as an alternative to a bioreactor.

Due to the extended use of conventional geometries to characterize complex heterogeneous fluids, the results should be taken with caution since factors such as sedimentation, non-homogeneity, slip, etc. may and indeed occur. Thus, the uses of more appropriate geometries seem to be the correct path to obtain reliable and consistent rheological results. The helicoidal geometry offers a solution to these kind of complex systems (EPNs) avoiding sedimentation and providing agitation to the media to improve homogeneity. Results are more reliable to provide optimum scaling factors for large scale applications.

Several authors suggest that for type of complex systems with high viscosity affect to mass, heat and momentum transfer processes [26]; for the systems studied here, it can be assumed that final nematode production by liquid fermentation could be restrained due to modifications in physical properties along process. Changes in viscosity affect oxygen dissolution and generate deficiencies in mixing causing poor nutrients availability and low matting frequency needed to induce sexual contact [27]. Finally, results suggest that rheological changes should be taken into account to select media, agitation system and vessel design in order to reach higher yields, this being critical in *Heterorhabditis bacteriophora* nematodes (EPNs) production at higher scale.

Conclusions

The use of a helicoidal ribbon agitator allowed the measure of rheological properties while maintaining homogeneity and avoiding sedimentation for the culture broth at several stages of insect pathogen *Heterorhabditis bacteriophora* nematodes (EPNs). It must be noted that other non-biological heterogeneous non-Newtonians fluids had been tested previously with this geometry.

The rheological properties n and K could be monitored during a long process and for mature cultures no matter the origin of samples or the nematode concentration; however, mature broths rheological properties presented certain dependency on nematode concentration. Non-Newtonian behaviour for culture broth viscosity was confirmed, and process viscosity for mature culture broths showed increases accordingly to the nematode concentration in the scope of rotational speed studied.

The results presented here are satisfactory and comparable with those reported for systems of similar nature. Procedure and method used could be applied to analyse and follow other kinds of microbial growths cultured in liquid systems.

Finally, the rheological parameters found here are applicable and

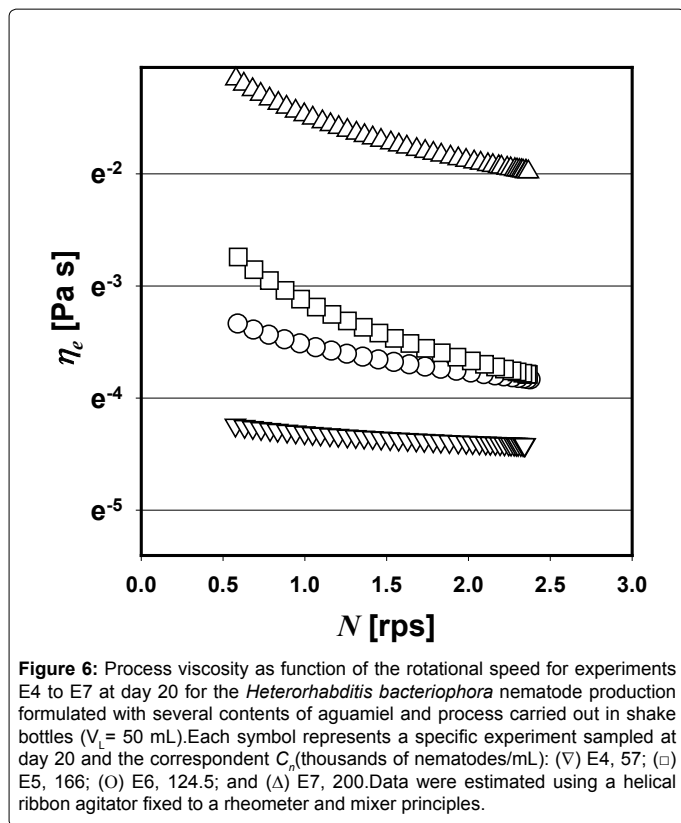

Figure 6: Process viscosity as function of the rotational speed for experiments E4 to E7 at day 20 for the *Heterorhabditis bacteriophora* nematode production formulated with several contents of aguamiel and process carried out in shake bottles ($V_b = 50$ mL). Each symbol represents a specific experiment sampled at day 20 and the correspondent C_n (thousands of nematodes/mL): (∇) E4, 57; (\square) E5, 166; (\circ) E6, 124.5; and (Δ) E7, 200. Data were estimated using a helical ribbon agitator fixed to a rheometer and mixer principles.

useful for nematode production process optimization: hydrodynamics characterization, bioreactor operation, downstream process, spraying final product in crops, and also for improving the scale up production.

References

- Georgis R, Gaugler R (1991) Predictability in biological control using entomopathogenic nematodes. *Journal of Economic Entomology* 84: 713-720.
- Ehlers RU (2001) Mass production of entomopathogenic nematodes for plant protection. *Appl Microbiol Biotechnol* 56: 623-633.
- Demain AL (2000) Microbial biotechnology. *Trends Biotechnol* 18: 26-31.
- Núñez Ramírez DM, Solís Soto A, Valencia-López JJ, Calderas F, López-Miranda J, et al. (2012) Study of the rheological properties in a fermentation broth of the fungus *Beauveria bassiana* in a Bioreactor under different hydrodynamic conditions. *J Microbiol and Biotechnol* 22: 1494-1500.
- Núñez Ramírez DM, Solís Soto A, Valencia-López JJ, Calderas F, López-Miranda J, et al. (2013) Mixing analysis for a fermentation broth of the fungus *Beauveria bassiana* in different hydrodynamic conditions in a bioreactor. *Chemical Engineering and Technology* 35: 1954-1961.
- Riley GL, Tucker KG, Paul GC, Thomas CR (2000) Effect of biomass concentration and mycelial morphology on fermentation broth rheology. *Biotechnol Bioeng* 68: 160-172.
- Galaction AI, Cascaval D, Oniscu C, Turnea M (2004) Enhancement of oxygen mass transfer in stirred bioreactors using oxygen-vectors. 1. Simulated fermentation broths. *Bioprocess Biosyst Eng* 26: 231-238.
- Young JM, Dunnill P, Pearce JD (1998) Physical properties of liquid nematode cultures and the design of recovery operations. *Bioprocess Eng* 19: 121-127.
- Shapiro-Ilan DI, Gaugler R (2002) Production technology for entomopathogenic nematodes and their bacterial symbionts. *J Ind Microbiol Biotechnol* 28: 137-146.
- Göğüs N, Tari C, Oncü S, Unluturk S, Tokatli F (2006) Relationship between morphology, rheology and polygalacturonase production by *Aspergillus sojae*

ATCC 20235 in submerged cultures. *Biochem Eng J* 32: 171-178.

- Müller C, Hansen K, Szabo P, Nielsen J (2003) Effect of deletion of chitin synthase genes on mycelial morphology and culture viscosity in *Aspergillus oryzae*. *Biotechnol Bioeng* 81: 525-534.
- Chavarría-Hernández N, Rodríguez-Hernández AI, Pérez-Guevara F, de la Torre M (2003) Evolution of culture broth rheological properties during propagation of the entomopathogenic nematode *Heterorhabditis* in submerged monoxenic culture. *Biotechnol Prog* 19: 405-409.
- Juárez-Sánchez M, Jiménez-Aparicio A, Gutiérrez-López G, Trejo-Tapia G, Rodríguez-Monroy M (2002) Broth rheology of *Beta vulgaris* cultures growing in an air lift bioreactor. *Biochem Eng J* 12: 37-41.
- Raposo S, Lima-Costa ME (2006) Rheology and shear stress of *Centaurea calcitrapa* cell suspension cultures grown in bioreactor. *Biotechnol Lett* 28: 431-438.
- Kemblowski Z, Kristiansen B (1986) Rheometry of fermentation liquids. *Biotechnol Bioeng* 28: 1474-1483.
- Brito-de la Fuente, Nava JA, Lopez MA, Medina L, Ascanio G, et al. (1998) Process viscometry of complex fluids and suspensions with helical ribbon agitators. *Canadian J Chem Eng* 76: 689-695.
- Badino Jr AC, Facciotti MCR, Schmidell W (2001) Volumetric oxygen transfer coefficients ($k_L a$) in batch cultivations involving non-Newtonian broths. *Biochem Eng J* 8: 111-119.
- Martínez-Padilla LP, Quemada D (2007) Baffled cup and end-effects of a vane-in-a-large cup rheometer for Newtonian fluids. *J Food Eng* 80: 24-32.
- Metzner AB, Otto RE (1957) Agitation of non-Newtonian fluids. *AIChE J* 3: 3-10.
- Islas-López MA, Sanjuan-Galindo R, Rodríguez-Hernández AI, Chavarría-Hernández N (2005) Monoxenic production of the entomopathogenic nematode *Steinernema carpocapsae* using culture media containing agave juice (aguamiel) from Mexican maguey-pulquero (*Agave* spp). Effects of the contents of nitrogen, carbohydrates and fat on infective juvenile production. *Appl Microbiol Biotechnol* 68: 91-97.
- Gaugler R, Grewal P, Kaya HK, Smith-Fiola D (2000) Quality assessment of commercially produced entomopathogenic nematodes. *Biological control* 17: 100-109.
- Steffe JF (1996) Rheological methods in food process engineering in food process engineering. Second edition. Freeman Press, USA.
- Inman III FL, Singh S, Holmes LD (2012) Mass production of the beneficial nematode *Heterorhabditis bacteriophora* and its bacterial symbiont *Photobacterium luminescens*. *Indian J Microbiol* 52: 316-324.
- Chavarría-Hernández N, Sanjuán-Galindo R, Rodríguez-Pastrana BR, Medina-Torres L, Rodríguez-Hernández AI (2007) Submerged monoxenic culture of the entomopathogenic nematode *Heterorhabditis* in an internal-loop bioreactor using two configurations of the inner tube. *Biotechnol Bioeng* 98: 167-176.
- Johnigk SA, Ehlers RU (1999) *Endotokia matricida* in hermaphrodites of *Heterorhabditis* spp. and the effect of the food supply. *Nematol* 1: 717-726
- Kilonzo PM, Margaritis A (2004) The effects of non-Newtonian fermentation broth viscosity and small bubble segregation on oxygen mass transfer in gas-liquid bioreactors: a critical review. *Biochem Eng J* 17: 27-40.
- Neves JM, Teixeira JA, Simões N, Mota M (2001) Effect of airflow rate on yields of *Steinernema carpocapsae* Az 20 in liquid culture in an external-loop airlift bioreactor. *Biotechnol Bioeng* 72: 369-373.

Citation: Nuñez-Ramírez DM, Medina-Torres L, Calderas F, Sanchez-Olivares G (2015) Properties of the Entomoparasitic Nematodes (*Heterorhabditis bacteriophora*) Liquid Culture using a Helicoidal Ribbon Agitator as Rheometric System. J Bioprocess Biotech 5: 207 doi:10.4172/2155-9821.1000207